

# RYNO<sup>®</sup> BENCH → FLOOR FIXING



*These instructions apply only when fixing to a concrete floor with no obstructions (e.g. under floor heating, cables, plumbing, etc.). When fixing to any other surface, or with obstructions, please contact your Pineapple representative for further advice*

## REQUIRED ITEMS

- 1x High power Drill
- 1x Floor fixing bracket (provided)
- 1x long 3/16 Drill bit (provided)
- 4x long security screws (provided)
- 1x 3/16 metal drill bit (provided)
- 4x appropriate floor fixing bolts
- Cutting Fluid





800.496.9324

[inquiries@pineapplecontracts.com](mailto:inquiries@pineapplecontracts.com)

# Pineapple

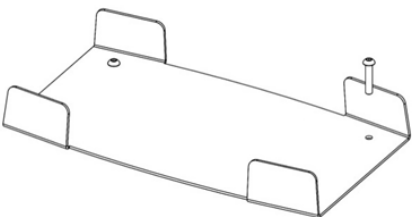
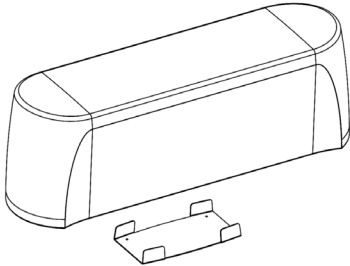
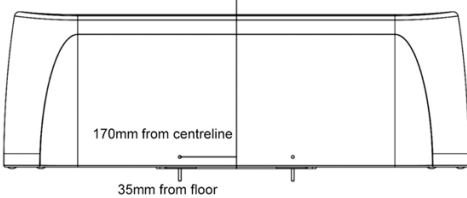
# RYNO<sup>®</sup> BENCH → FLOOR FIXING

<h2>01</h2>	<p>Place metal bracket on the floor with the bench over the top and position to where needed</p>	
	<p>Remove bench and affix bracket to the floor using the correct hardware</p>	<h2>02</h2>
<h2>03</h2>	<p>Place bench over the bracket</p>	
	<p>Mark two points 35mm(1.4in) from the floor and 170mm(6.7in) from the centerline of each bench. Mark the points on both sides</p>	<h2>04</h2>

# RYNO<sup>®</sup> BENCH → FLOOR FIXING

05

With the bench in place drill through all 4 points until a hole is started in the metal floor fixing plate. Use the long 3/16 Drill bit provided. (Use cutting fluid and the drill at a low speed)

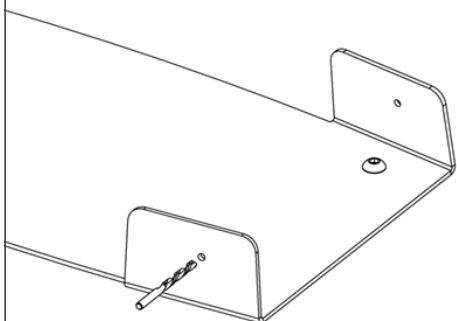

Remove the bench and drill through the remainder of the steel plate using the shorter 3/16 drill bit. (Use cutting fluid and the drill at a low speed)

06

07

Place the bench back over the bracket and align all the holes

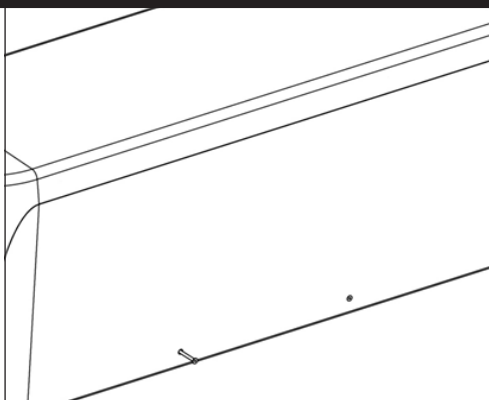

Use the provided long security screws in each of the 4 holes Ensuring the heads end up flush with the side of the bench

08



800.496.9324

[inquiries@pineapplecontracts.com](mailto:inquiries@pineapplecontracts.com)

**Pineapple**

# DISCLAIMER

- Ensure the proper and adequate hardware is used to secure furniture
- Ensure fastenings are appropriate for the anchoring material
- Use fastenings of an appropriate strength and consider using security fixings in challenging environments
- Consider using high strength thread-locker on fastenings in challenging environments
- Ensure all gaps are sealed with the appropriate anti-pick caulk after product installation if necessary
- Please read all instructions carefully to ensure proper installation. Failure to read and follow instructions may result in inadequate product installation and void of warranty
- Pineapple shall not be held liable for any consequences caused by the improper installation of products to the installer or the end user



800.496.9324

[inquiries@pineapplecontracts.com](mailto:inquiries@pineapplecontracts.com)

**Pineapple**