

TV CABINETS

→ WALL MOUNTING



These instructions apply only when fixing to a concrete floor, or brick wall, with no obstructions (e.g. under floor heating, cables, plumbing, etc.). When fixing to any other surface, or with obstructions, please contact your Pineapple representative for further advice

REQUIRED ITEMS

- 9 x suitable wall anchors
- 6 x appropriate fixings
- 1 x wood drill bit (10mm)
- 1 x masonry drill bit (for use with hardware fastenings)
- Handheld power drill
- Spirit level



800.496.9324

inquires@pineapplecontracts.com

Pineapple

TV CABINETY

→ WALL MOUNTING

01

Place TV cabinet in position, using a level. For best results, place cabinet so that sockets and aerial cables are located within the cabinet

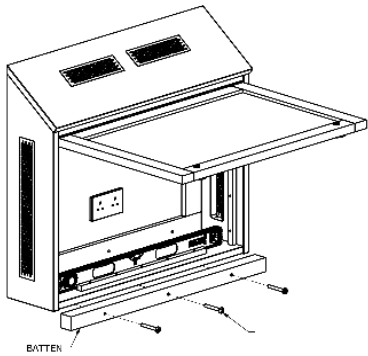
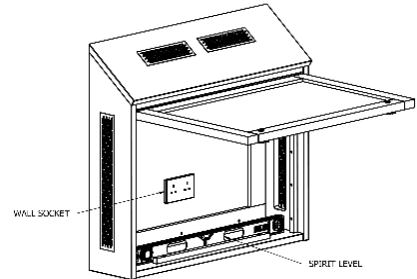

If the wall has insufficient fixing strength, a batten may be applied underneath for additional support

02

03

Open the door and drill pilot holes in top and bottom plinths (3 holes in each)

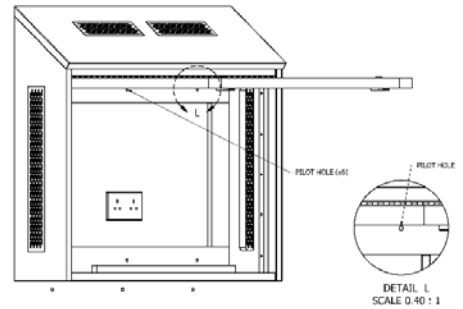

Remove TV cabinet

04



800.496.9324

inquires@pineapplecontracts.com

Pineapple

TV CABINETS

→ WALL MOUNTING

05

Drill holes in wall and insert appropriate hardware

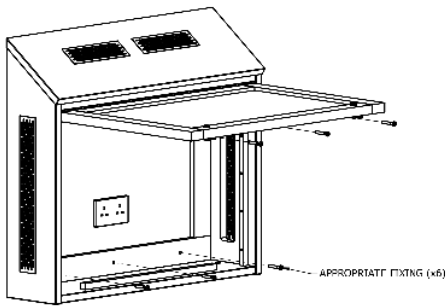
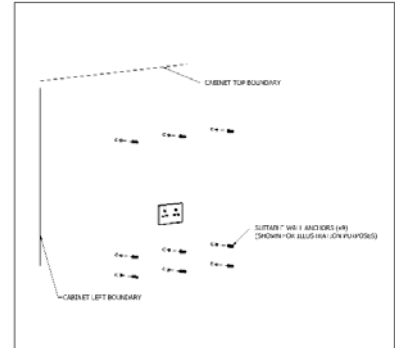

Place TV cabinet back into position and secure with appropriate fixings

06



800.496.9324

inquires@pineapplecontracts.com

Pineapple

DISCLAIMER

	<ul style="list-style-type: none">→ Ensure the proper and adequate hardware is used to secure furniture→ Ensure fastenings are appropriate for the anchoring material→ Use fastenings of an appropriate strength and consider using security fixings in challenging environments→ Consider using high strength thread-locker on fastenings in challenging environments→ Ensure all gaps are sealed with the appropriate anti-pick sealant after product installation if necessary→ Please read all instructions carefully to ensure proper installation. Failure to read and follow instructions may result in inadequate product installation and void of warranty→ Pineapple shall not be held liable for any consequences caused by the improper installation of products to the installer or the end user→ All products must be secured to the wall and not freestanding to avoid risk of injury



800.496.9324

inquires@pineapplecontracts.com