

SIGMA TUB CHAIR

1SIG1-100

31.5H | 31.5W | 27.9D (")

Seat Height: 17.3"

Weight: 23kg



KEY FEATURES

- Wrap-around design of the seat back provides comfort and support
- Compact footprint helps you make the most of your available space
- Double top-stitched seams for strength and appearance
- Fixed seat cushion to prevent misuse



MATERIAL/FABRICATION

The Sigma range is constructed from plywood and softwood. A fixed seating platform and enclosed base panel helps reduce concealment opportunities. Fixed upholstered cushioned seat is made from fire retardant, CMHR (combustion modified high resilience) foam is safe for both users and staff.

TEST STANDARDS

- BS EN 16139:2013 level 2 (Max weight capacity = 31 stone/200kg)
- Fabrics fire retardancy - BS 7176:2007 Source 5

OPTIONS

- Also available in a Sigma Plus range
- Available as Sigma 2-Seater option (see below)

1SIG2-100
31.5H | 53.1W | 27.9D (")
Seat Height: 17.3"
Weight: 33kg



FINISH

High impact black plastic feet as standard, secured via security screws

FABRICS

Available in a wide choice of fabrics including Vinyl, Waterproof, Non Waterproof and Leather

ASSEMBLY

Arrives assembled and ready to use

DELIVERY

Leadtime approx 8 weeks

INSTALLATION/FITTING

No fitting required

MAINTENANCE

See our care guidelines for more information <https://us.pineapplecontracts.com/upholstery/care-guidance/>

WARRANTY

5 year guarantee (does not include fabrics)

SIGMA TUB CHAIR

1SIG1-100

31.5H | 31.5W | 27.9D (")

Seat Height: 17.3"

Weight: 23kg

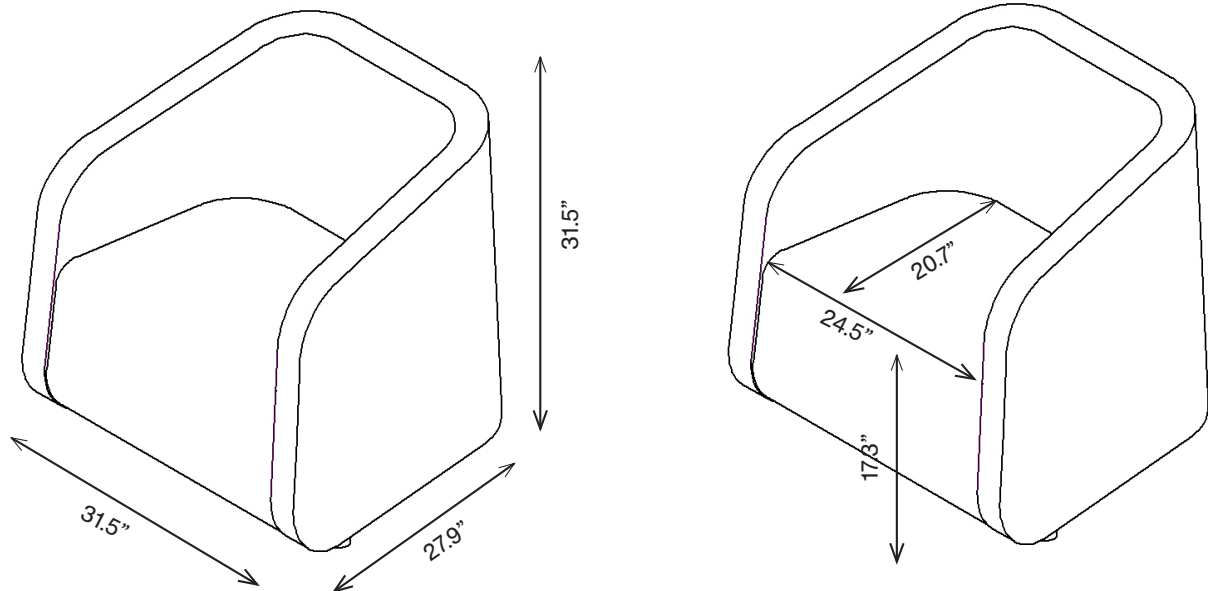

T
E
W

+ 800.496.9324

inquiries@pineapplecontracts.com

us.pineapplecontracts.com

Pineapple