



KEY FEATURES

- Plywood reinforcement, including a fully enclosed base to prevent concealment
- Wrap-around design of the seat back gives great comfort and support for users
- Compact footprint helps you make the most of your available space



MATERIAL/FABRICATION

Additional weight and reinforcement, no piping or buttons and has an enclosed base. Security screws, non-accessible staples to deter misuse, and other features include a fixed seat cushion, to prevent concealment. Double top-stitched seams for strength and appearance. Fixed upholstered cushioned seat made from fire retardant, CMHR (combustion modified high resilience) foam is safe for both users and staff. Interior made from fire retardant, CMHR foam is safe for both users and staff. All fabric is fire retardant to CAL TB 116, 117 & NFPA 260 USA

TEST STANDARDS

- Fire retardant to BS7176:2007 source 5
- Strength and stability tested to BS EN 16139:2013
- (seat and back durability tested for 200,000 cycles)
-

OPTIONS

- Also available as standard model

COLOUR/FINISH

Feet come in natural as standard

FABRIC

A wide choice of waterproof vinyls and fabrics

ASSEMBLY

Arrives assembled and ready to use

INSTALLATION/FITTING

No fitting required

MAINTENANCE

See upholstered furniture section of our online care guidelines

WARRANTY

5 year guarantee (does not include fabrics)

SIGMA PLUS

2-SEATER

1SIGP2-400

31.5"H | 53.1"W | 27.9"D

Seat Height: 17.3"

Weight: 112.4 lbs.

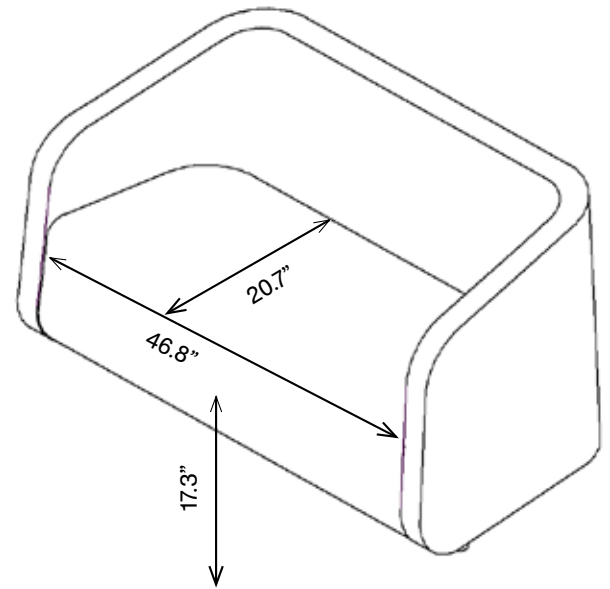
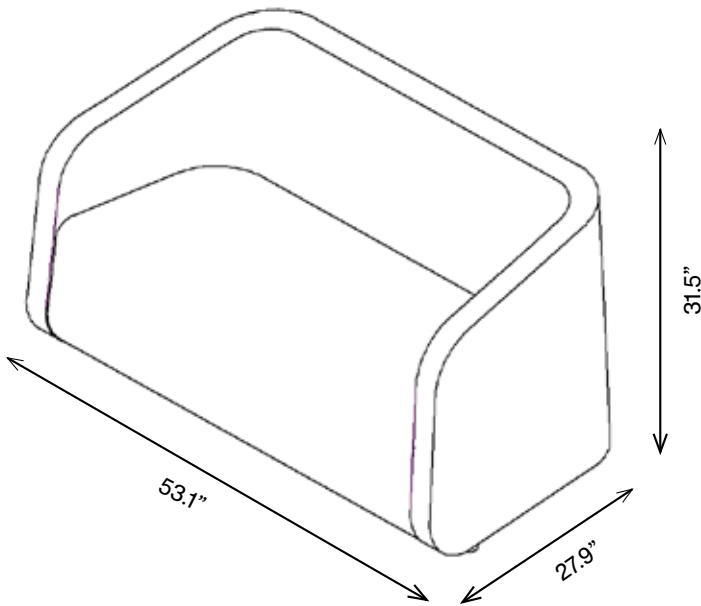

T
E
W

800.496.9324

inquiries@pineapplecontracts.com

us.pineapplecontracts.com

Pineapple