

SEAL 2-SEATER

1SAS2-00

33.1"H | 59.1"W | 27.6"D

Seat Height: 15"

Weight: 99 lbs.



KEY FEATURES

- Designed without seams or gaps to minimize concealment opportunities
- Anti-concealment base with non-accessible fixings
- Subtle arms support staff in safe de-escalation practices
- Water-resistant, hygienic outer skin which can be easily cleaned and dried for re-use
- Seat static load tested to 500 lbs.

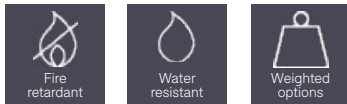

Azur Blue:



London Gray:



MATERIAL/FABRICATION

Made without seams or gaps, Seal is a minimalist seating range designed to reduce risk and maximize safety in challenging environments. Seal's soft foam core is protected by a water-resistant outer skin, creating a hygienic surface which can be easily cleaned and dried, ready for re-use.

SOFT-TEC™ is a 2-part molded polyurethane material (internal foam density 176 lbs./m³) which combines soft comfort with resistance and durability. It is extremely resistant to wear, tearing, shocks, laceration and abrasions.

TEST STANDARDS

- Static load test (seat) 500 lbs. (EN 16139:2013 Level 2)
- Flame retardant SOFT-TEC™ material (BS 5852-2:1982 - Crib 5)

OPTIONS

- Additional weighted 2-Seater option available (198 lbs.)

COLOR/FINISH

Available in dual-tone Azur Blue or London Gray color options

ASSEMBLY

Arrives assembled and ready to use

INSTALLATION/FITTING

No fitting required

MAINTENANCE

SOFT-TEC™ is easily cleaned with a 0.1% sodium hypochlorite solution as recommended for healthcare settings. The material is lead and phthalate-free, resistant to mildew and complies with Reach Art. 33 for presence of SVHC. For recommended cleaners and further instructions please contact our team at inquiries@pineapplecontracts.com

WARRANTY

5 year guarantee

T

800.496.9324

E

inquiries@pineapplecontracts.com

W

us.pineapplecontracts.com

Pineapple

SEAL 2-SEATER

1SAS2-00

33.1"H | 59.1"W | 27.6"D

Seat Height: 15"

Weight: 99 lbs.

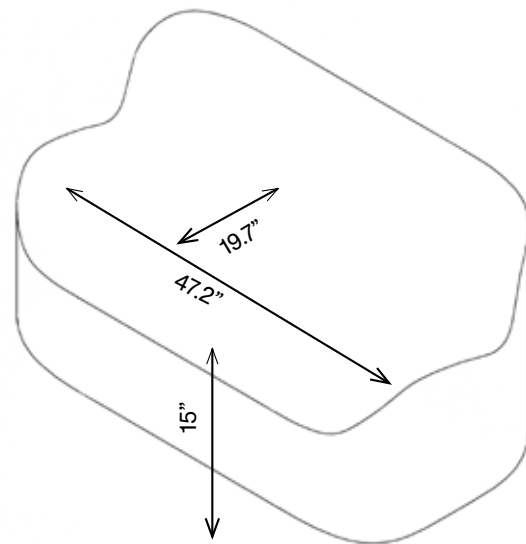
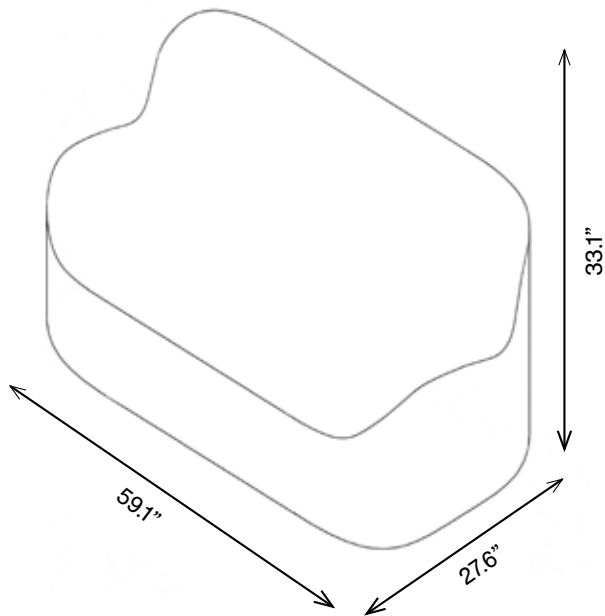

T
E
W

800.496.9324

inquiries@pineapplecontracts.com

us.pineapplecontracts.com

Pineapple