

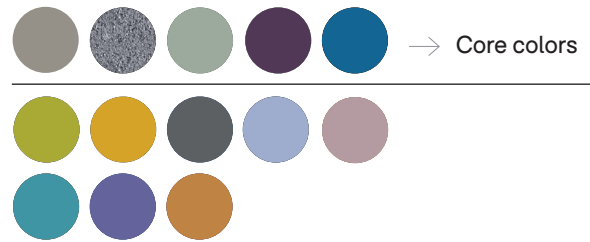

KEY FEATURES

- Heavily weighted to 271lbs to deter mishandling
- Strength and stability tested for severe contract use
- Integrated drainage channel allows water run-off
- Suitable for 2 people/bariatric user
- Water-resistant, UV stabilized material - suitable for outdoor use
- Hygienic wipe-clean surface
- Lifetime guarantee against manufacturing faults



MATERIAL/FABRICATION

Rotationally moulded, durable polyethylene, one-piece construction provides excellent strength and stability. Flamed, textured finish further strengthens the fire-retardant, water-resistant, UV-stabilized shell, ideal to be used indoors and outdoors. Hygienic wipe-clean surface, quick to dry ready to be used again quickly. Sloped arms and low back designed to minimize ligature risks. Item is fully recyclable as polyethylene can be melted down to create a whole new product.

TEST STANDARDS

- Fire retardant to CAL 133 and UL 94 HB
- Strength and Stability tested to BS EN 16139:2013 - Test level 2
- UV resistance tested to UV 21+ stating it can withstand 21,000 sunlight hours

OPTIONS

- Floor fixing solution
- Anti-stash base cover plate available
- Lightweight model (77lb) - 1RY2-00
- Weighted model (271lb) - 1RY2-118

COLOR/FINISH

[Core colors] Moonwalk Grey, Granite, Cool Green, Icon Purple, Epic Blue, [Other available colors] Lime Green, Vegas Yellow, Thunder Grey, Dusty Blue, Dusty Pink, Teal, Violet Purple and Warm Terracotta

ASSEMBLY

Arrives assembled and ready to use

INSTALLATION/FITTING

Additional weighting can be carried out prior to delivery. Please advise if floor fixing is required when ordering as fixed items are made differently. All products must be fitted carefully following Pineapple's product instructions (where available). If not, any guarantee is at risk of becoming null and void

MAINTENANCE

Our multi-purpose Ryno cleaning wipes are available to help keep your Ryno products looking their best. Avoid using abrasive materials or cleaning agents, solvents, steam cleaning or jet washing. Use bleach and chlorine disinfectant with caution and avoid placing in close proximity to sources of heat. Read more here <https://us.pineapplecontracts.com/upholstery/care-guidance/>

WARRANTY

Lifetime guarantee against all manufacturing faults

DISCLAIMER

Extreme temperature changes (e.g. a cold night followed by a warm sunny day) may cause air inside the product to expand, causing short-term changes to its shape .

Due to the nature of the rotational moulding process, flat surfaces on Ryno® products may feature slight undulations which do not detract from the product's strength or durability.

There will be some color variation from batch to batch this is the nature of the reclaim polymer.

RYNO[®] 2-SEATER

1RY2-00/1RY2-118

31.9"H | 58.9"W | 26.5"D (in)

Seat height: 17.1 in

Weight: 77lbs or 271lbs

1RY2
31.88H | 58.89W | 26.53D (in)

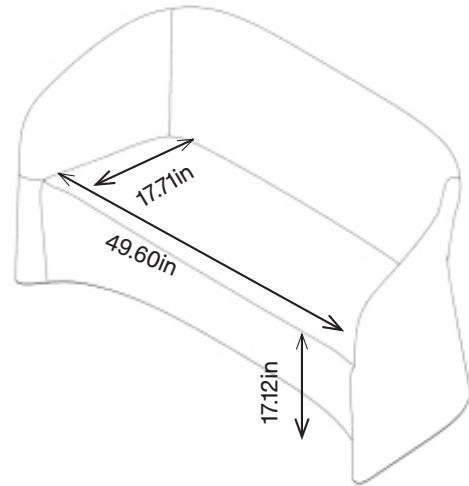
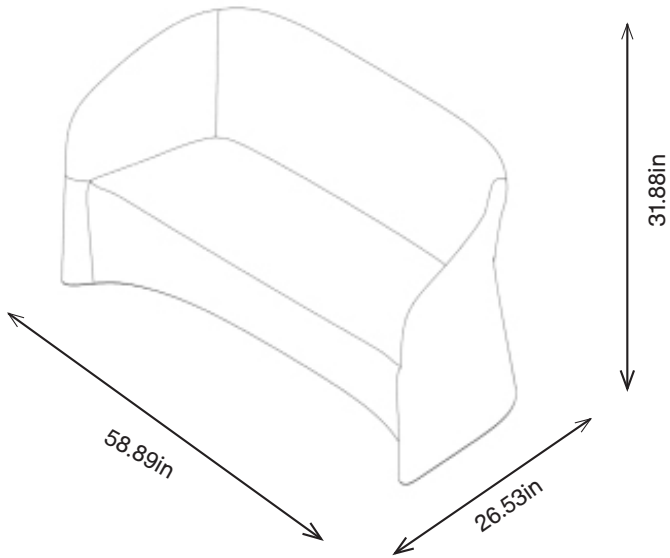

T
E
W

800.496.9324

inquires@pineapplecontracts.com

us.pineapplecontracts.com

Pineapple