

LEVO RECLINER

DISASSEMBLY & CLEANING INSTRUCTIONS



Please Note:
Heavyweight item; 2
people required for lifting



Please read all instructions carefully before attempting to disassemble this product. If you have any queries or concerns, please contact your Pineapple representative for further advice

REQUIRED ITEMS

- Screwdriver with security torix bits
- Small plinth (approx. 600x600x600(mm) or use a furniture blanket

NB. This should be carried out by at least 2 people due to the product being heavyweight



800.496.9324

inquiries@pineapplecontracts.com

Pineapple

LEVO RECLINER

DISASSEMBLY & CLEANING INSTRUCTIONS



Please Note:
Heavyweight item; 2
people required for lifting

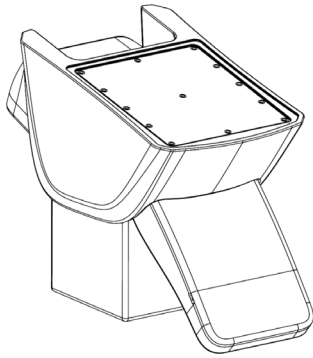

Place recliner upturned on a plinth if possible, or on a furniture blanket to protect the upholstery and arms. Ensure the recliner is as open as possible.

01

02

Remove x13 security screws and the metal base plate.

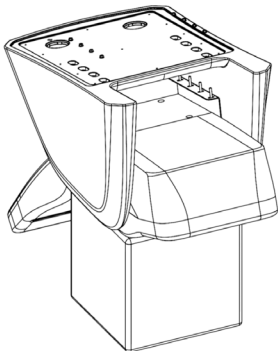
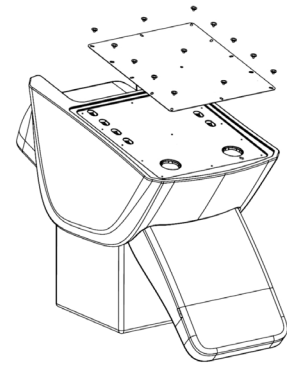

Undo x8 nuts/bolts that affix the mechanism and upholstery assembly from the arms and carefully lift clear. Take care not to scratch the arms as the mechanism is removed.

03



800.496.9324

inquiries@pineapplecontracts.com

Pineapple

LEVO RECLINER

DISASSEMBLY & CLEANING INSTRUCTIONS



Please Note:
Heavyweight item; 2
people required for lifting

04

Clean and dry both the upholstered mechanism and the recliner arms.

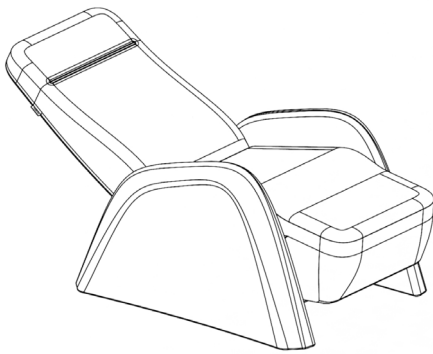
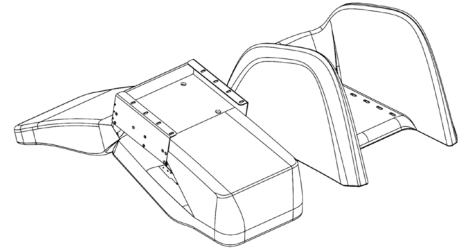

Follow instructions in reverse order for reassembly.

05



800.496.9324

inquiries@pineapplecontracts.com

Pineapple

DISCLAIMER

	<ul style="list-style-type: none">→ Ensure the proper and adequate hardware is used to secure furniture→ Ensure fastenings are appropriate for the anchoring material→ Use fastenings of an appropriate strength and consider using security fixings in challenging environments→ Consider using high strength thread-locker on fastenings in challenging environments→ Ensure all gaps are sealed with the appropriate anti-pick mastic after product installation if necessary→ Please read all instructions carefully to ensure proper installation. Failure to read and follow instructions may result inadequate product installation and void of warranty→ Pineapple shall not be held liable for any consequences caused by the improper disassembly or installation of products to the installer or the end user



800.496.9324

inquiries@pineapplecontracts.com

