

# RYNO<sup>®</sup> WALL MOUNTED DESK → WALL FIXING



*These instructions apply only when fixing to a brick wall with no obstructions (e.g. cables, plumbing, etc.). When fixing to any other surface, or with obstructions, please contact your Pineapple representative for further advice*

## REQUIRED ITEMS

- Wall mounting batten
- 5 x large wall hardware fixings (batten)
- 8 x wall hardware fixings and washers (product)
- Handheld power drill
- Tools for wall fixing hardware
- Drill bit for wall fixing hardware





800.496.9324

[inquiries@pineapplecontracts.com](mailto:inquiries@pineapplecontracts.com)

# Pineapple

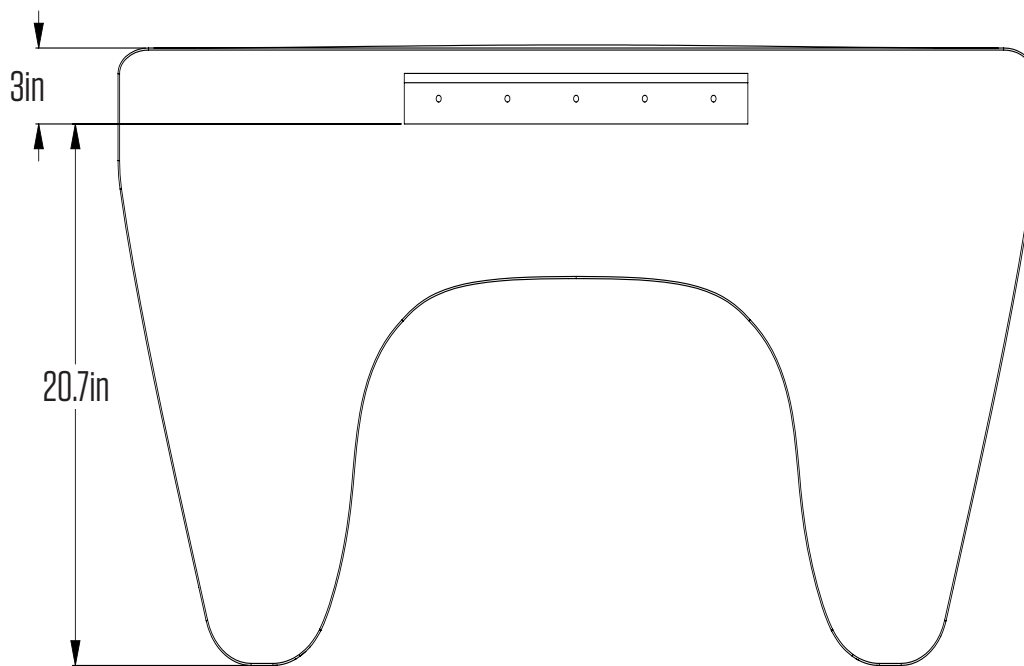
# RYNO<sup>®</sup> WALL MOUNTED DESK → WALL FIXING



800.496.9324

[inquiries@pineapplecontracts.com](mailto:inquiries@pineapplecontracts.com)

**Pineapple**

# RYNO<sup>®</sup> WALL MOUNTED DESK → WALL FIXING

01

Mark position of batten for correct location of unit

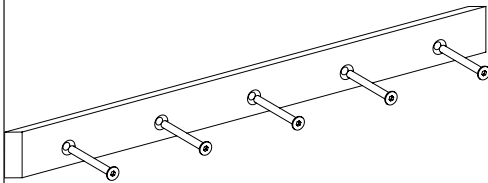
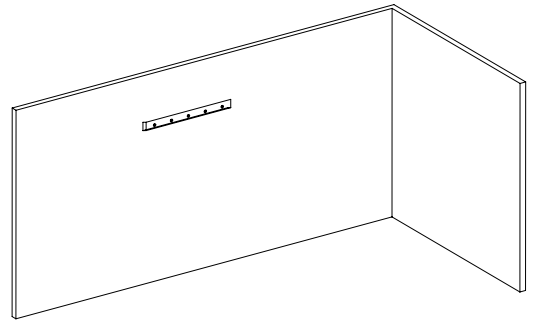

Attach batten to wall using suitable load bearing wall fixings

02

03

Hang wall unit onto batten, ensuring it is seated correctly and unit is horizontal

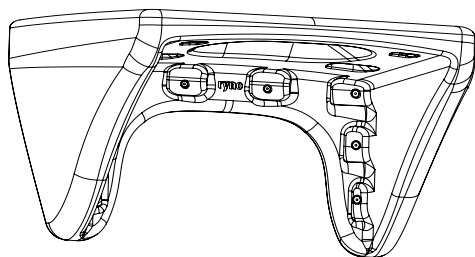
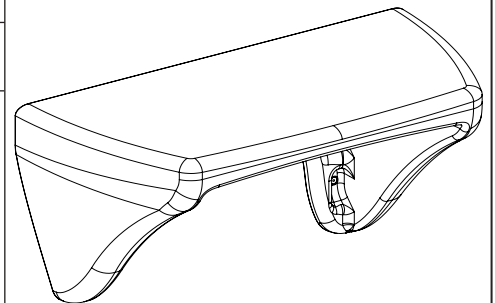

Drill through fixing points with a pilot drill and install suitable hardware into the wall

04

T  
E

800.496.9324

[inquiries@pineapplecontracts.com](mailto:inquiries@pineapplecontracts.com)

**Pineapple**

# RYNO<sup>®</sup> WALL MOUNTED DESK → WALL FIXING

05

Drill appropriately sized holes through wall unit and secure to wall using suitable fixings and washers

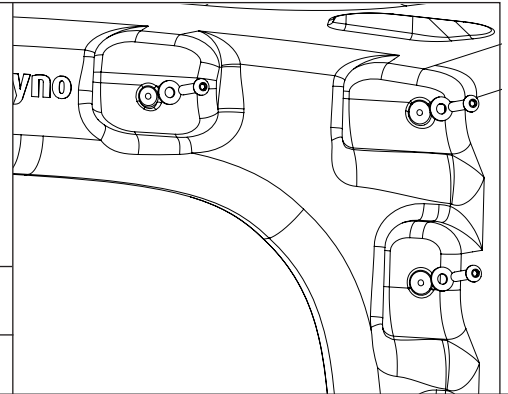

T  
E

800.496.9324

[inquiries@pineapplecontracts.com](mailto:inquiries@pineapplecontracts.com)

**Pineapple**

# DISCLAIMER

	<ul style="list-style-type: none"><li>→ Ensure the proper and adequate hardware is used to secure furniture</li><li>→ Ensure fixings are appropriate for the anchoring material</li><li>→ Use fixings of an appropriate strength and consider using security fixings in challenging environments</li><li>→ Consider using high strength thread-locker on fixings in challenging environments</li><li>→ Ensure all gaps are sealed with the appropriate anti-pick caulk after product installation if necessary</li><li>→ Please read all instructions carefully to ensure proper installation. Failure to read and follow instructions may result in inadequate product installation and void of warranty</li><li>→ Pineapple shall not be held liable for any consequences caused by the improper installation of products to the installer or the end user</li></ul>



800.496.9324

[inquiries@pineapplecontracts.com](mailto:inquiries@pineapplecontracts.com)

**Pineapple**