

ADORA PLUS

ARM REMOVAL INSTRUCTIONS

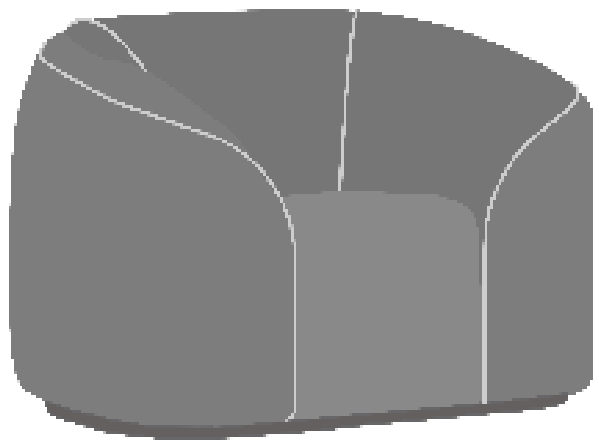

Please Note:
Heavyweight item; 2
people required for lifting



Please read all instructions carefully before attempting to disassemble this product. If you have any questions or concerns, please contact your Pineapple representative for further advice

REQUIRED ITEMS

- Screwdriver with security torix bits
- Small plinth (approx. 24x24x24(in) or use a furniture blanket

NB. This should be carried out by at least 2 people due to the product being heavyweight



800.496.9324

inquiries@pineapplecontracts.com

Pineapple

ADORA PLUS

ARM REMOVAL INSTRUCTIONS



Please Note:
Heavyweight item; 2
people required for lifting

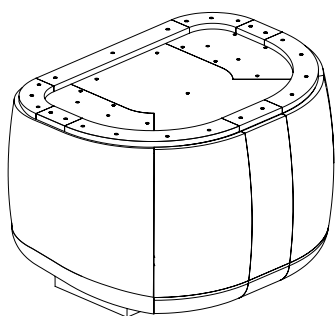

Place the armchair upturned on a plinth if possible, or on a furniture blanket to protect the upholstery and arms.

01

02

Remove x23 security screws and the feet.

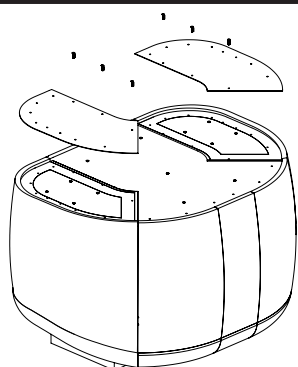
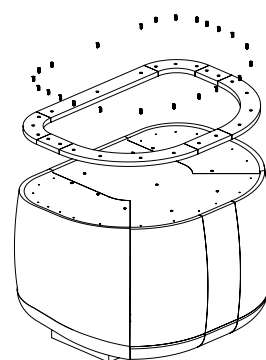

Remove the cardboard panels from the arm sections (6 screws, 3 for each).

03



800.496.9324

inquiries@pineapplecontracts.com

Pineapple

ADORA PLUS

ARM REMOVAL INSTRUCTIONS



Please Note:
Heavyweight item; 2
people required for lifting

04

Remove the internal base panel from the arm sections (8 screws, 4 for each).

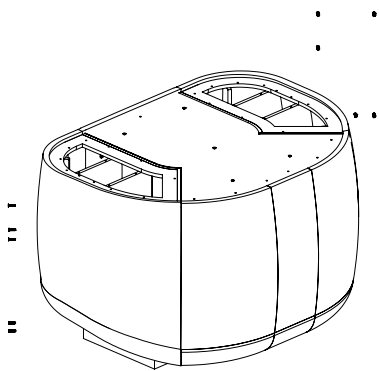
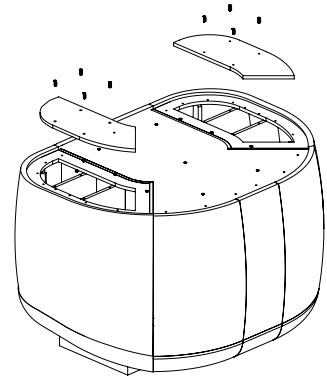

Unbolt the arms from the backrest section (10 bolts, 5 for each).

05

06

Unbolt the arms from the seat section and remove them (8 bolts 4 for each).

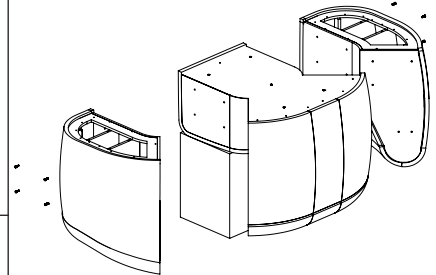

Follow the instructions in reverse order for reassembly.

07



800.496.9324

inquiries@pineapplecontracts.com

Pineapple

DISCLAIMER

	<ul style="list-style-type: none">→ Ensure the proper and adequate hardware is used to secure furniture→ Ensure fastenings are appropriate for the anchoring material→ Use fastenings of an appropriate strength and consider using security fixings in challenging environments→ Consider using high strength thread-locker on fastenings in challenging environments→ Ensure all gaps are sealed with the appropriate anti-pick caulk after product installation if necessary→ Please read all instructions carefully to ensure proper installation. Failure to read and follow instructions may result in inadequate product installation and void of warranty→ Pineapple shall not be held liable for any consequences caused by the improper disassembly or installation of products to the installer or the end user



800.496.9324

inquiries@pineapplecontracts.com

