



## KEY FEATURES

- Heavily weighted to 313lbs to deter misuse
- Wheelchair accessible design
- Hygienic wipe-clean material
- Material compliant with flammability standards UL94 HB & BS 5852:2006
- Base is optionally made from 40% recycled content
- Base is 100% recyclable



### MATERIAL/FABRICATION

The base is a rotationally molded, durable polyethylene, one-piece construction provides excellent strength and stability. Flamed, textured finish further strengthens the fire-retardant, water-resistant, UV-stabilized shell.

Tabletop available in Natural Rockford Hickory with an anti-spill PU Moonwalk Gray edge. Available as a weighted option (313lbs) which deters lifting, the base is also floor fixable with a secure hidden floor fixing solution.

Tabletop Edge: Moonwalk Gray

Laminate options: Natural Rockford Hickory or Gray

### OPTIONS

- Anti-tamper floor fixed option
- Optionally made with 40% reused content
- 37.8 x 37.8 (in) tabletop available
- Also available as a double pedestal table 94.5 x 47.2 (in) option with an increased seating capacity of 8 (see below)



### TEST STANDARDS

- Fire retardant to CAL 133 and UL 94 HB
- Fire retardant to BS 5852:2006 ignition source 5

### COLOR/FINISH

CORE COLORS



NON-POROUS COLORS



LAMINATE TOP OPTIONS



## ASSEMBLY

Arrives assembled and ready to use

## INSTALLATION/FITTING

Additional weighting can be carried out prior to delivery. Please advise if floor fixing is required when ordering as fixed items are made differently. All products must be fitted carefully following Pineapple's product instructions (where available). If not, any guarantee is at risk of becoming null and void

## MAINTENANCE

Avoid using abrasive materials or cleaning agents, solvents, steam cleaning or jet washing. Use bleach and chlorine disinfectant with caution and avoid placing in close proximity to sources of heat. Read more here <https://us.pineapplecontracts.com/upholstery/care-guidance/>

## WARRANTY

Lifetime guarantee against all manufacturing faults

## DISCLAIMER

Extreme temperature changes (e.g. a cold night followed by a warm sunny day) may cause air inside the product to expand, causing short-term changes to its shape.

Due to the nature of the rotational molding process, flat surfaces on Ryno® products may feature slight undulations which do not detract from the product's strength or durability.

Floor fixable options cannot be additionally weighted as the necessity to floor fix for immovability negates any need for internal weight to be added.

**1RYTP1**  
31.5H | 37.8W | 37.8D (in)  
Standard weight: 70.5lbs  
Weighted option: 264.5lbs  
Seating capacity: 2-4

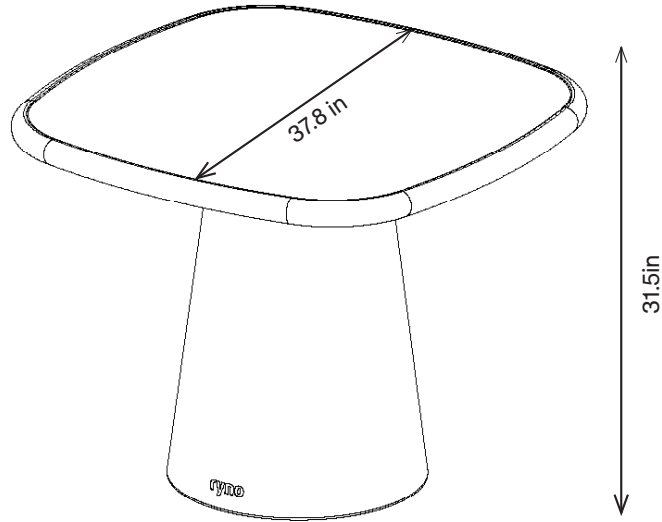

**1RYPT4**  
31.5H | 47.2W | 47.2D (in)  
Standard weight: 119lbs  
Weighted option: 313lbs  
Seating capacity: 4

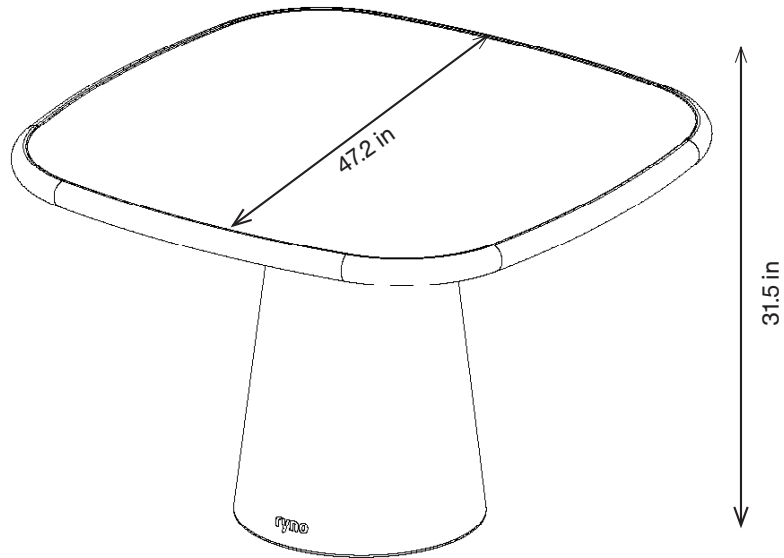

# RYNO<sup>®</sup> COMBO TABLE

## 1RYPT6

31.5H | 94.5W | 47.2D (in)

Standard weight: 218.2lbs

Weighted option: 606.3lbs

Seating capacity: 8

