

MAGNA 2.0 3-SEATER

1MG3-200

30.3H | 68.2W | 33.5D (in)

Seat Height: 17.6in

Weight: 180.8lb



KEY FEATURES

- Reinforced seat platform as standard for improved durability
- Improved comfort and aesthetics
- Fixed seat and back cushions to prevent misuse
- Strength and stability tested for severe contract use



MATERIAL/FABRICATION

Carcass made from a mix of particle board and plywood with curved feet or a plinth base as found on our Plus range, which prevents dust and dirt gathering underneath. Strong plywood reinforcement offers excellent levels of durability and strength. All cushions fixed to the base to ensure that they are not taken off with anti-stash seams option to prevent hiding of contraband. Cushioned areas made from fire retardant, CMHR (combustion modified high resilience) foam is safe for both users and staff.

TEST STANDARDS

- Fire retardant to BS7176:2007 source 5
- EN 16139: 2013, Test Level 2 (for adults weighing up to 243lbs)
- Strength, Durability and Safety requirements for non-domestic seating ANSI / BIFMA X5.4-2020

OPTIONS

- Available in armchair, 2-Seater and 3-Seater options
- Available in Standard or Plus levels or reinforcement
- Plinth version is only available on the Plus range
- Floor fitting is only available on the Plus version with a Plinth
- 'Zero-depth' seams option available on Magna Plus models to prevent concealment (1MG1-900)

COLOR/FINISH

Base options come in a Solid Birchwood with a Natural Lacquer finish

FABRIC

Available in a wide choice of fabrics including Vinyl, Waterproof, Non Waterproof and Leather

ASSEMBLY

Arrives assembled and ready to use

INSTALLATION/FITTING

No fitting required

MAINTENANCE

See upholstered furniture section of our care guidelines <https://us.pineapplecontracts.com/upholstery/care-guidance/>

WARRANTY

7 year guarantee (does not include fabrics)

T
E
W

800.496.9324

inquiries@pineapplecontracts.com

us.pineapplecontracts.com

Pineapple

MAGNA 2.0 3-SEATER

1MG3-200

30.3H | 68.2W | 33.5D (in)

Seat Height: 17.6in

Weight: 180.8lb

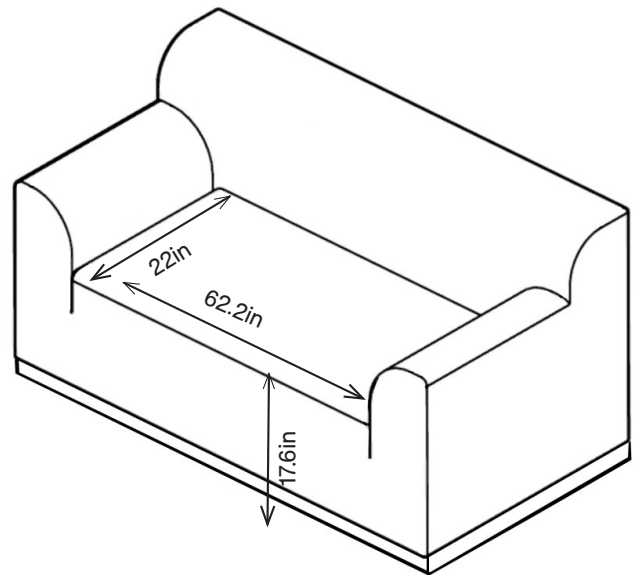
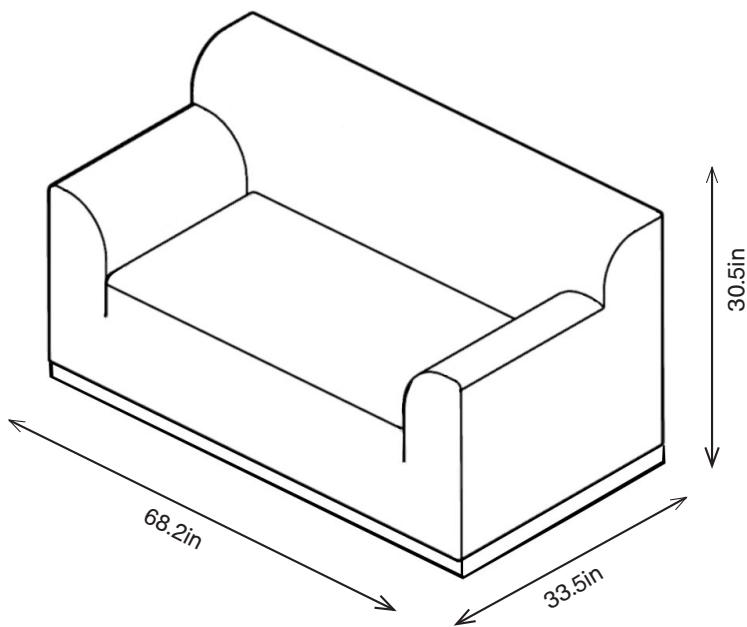

T

800.496.9324

E

inquiries@pineapplecontracts.com

W

us.pineapplecontracts.com

Pineapple