

# MAGNA 2.0 PLUS 2-SEATER

1MG2-9118  
30.3H | 53.2W | 33.5D (in)  
Seat Height: 17.6in  
Weight: 209.4lb



## KEY FEATURES

- Plywood reinforcement for added strength
- 'Zero-depth' seams prevent concealment
- Fully enclosed base to prevent concealment
- Fixed seat and back cushions to prevent misuse
- Additionally weighted to deter misuse
- Strength and stability tested for severe contract use



### MATERIAL/FABRICATION

Carcass made from a mix of particle board and plywood with plinth base on our Plus range, which prevents dust and dirt gathering underneath. Strong plywood reinforcement offers excellent levels of durability and strength. All cushions fixed to the base to ensure that they are not taken off with anti-stash seams option to prevent hiding of contraband. Cushioned areas made from fire retardant, CMHR (combustion modified high resilience) foam is safe for both users and staff.

### TEST STANDARDS

- Fire retardant to BS7176:2007 source 5
- EN 16139: 2013, Test Level 2 (for adults weighing up to 243lbs)
- Strength, Durability and Safety requirements for non-domestic seating ANSI / BIFMA X5.4-2020
- Static load internally tested up to 1 ton (2200lbs)

### OPTIONS

- Available in armchair, 2-Seater and 3-Seater options
- Available in Standard or Plus levels or reinforcement
- Choose from Feet (1MG1-200) or a Plinth base design (1MG1-9118)
- Plinth version is only available on the Plus range
- Floor fitting is only available on the Plus version with a Plinth

### COLOR/FINISH

Base options come in a Solid Birchwood with a Natural Lacquer finish

### FABRIC

Available in a wide choice of fabrics including Vinyl, Waterproof, Non Waterproof and Leather

### ASSEMBLY

Arrives assembled and ready to use

### INSTALLATION/FITTING

No fitting required

### MAINTENANCE

See upholstered furniture section of our care guidelines <https://us.pineapplecontracts.com/upholstery/care-guidance/>

### WARRANTY

7 year guarantee (does not include fabrics)

T

800.496.9324

E

[inquiries@pineapplecontracts.com](mailto:inquiries@pineapplecontracts.com)

W

[us.pineapplecontracts.com](https://us.pineapplecontracts.com)

# Pineapple

# MAGNA 2.0 PLUS 2-SEATER

1MG2-9118

30.3H | 53.2W | 33.5D (in)

Seat Height: 17.6in

Weight: 209.4lb

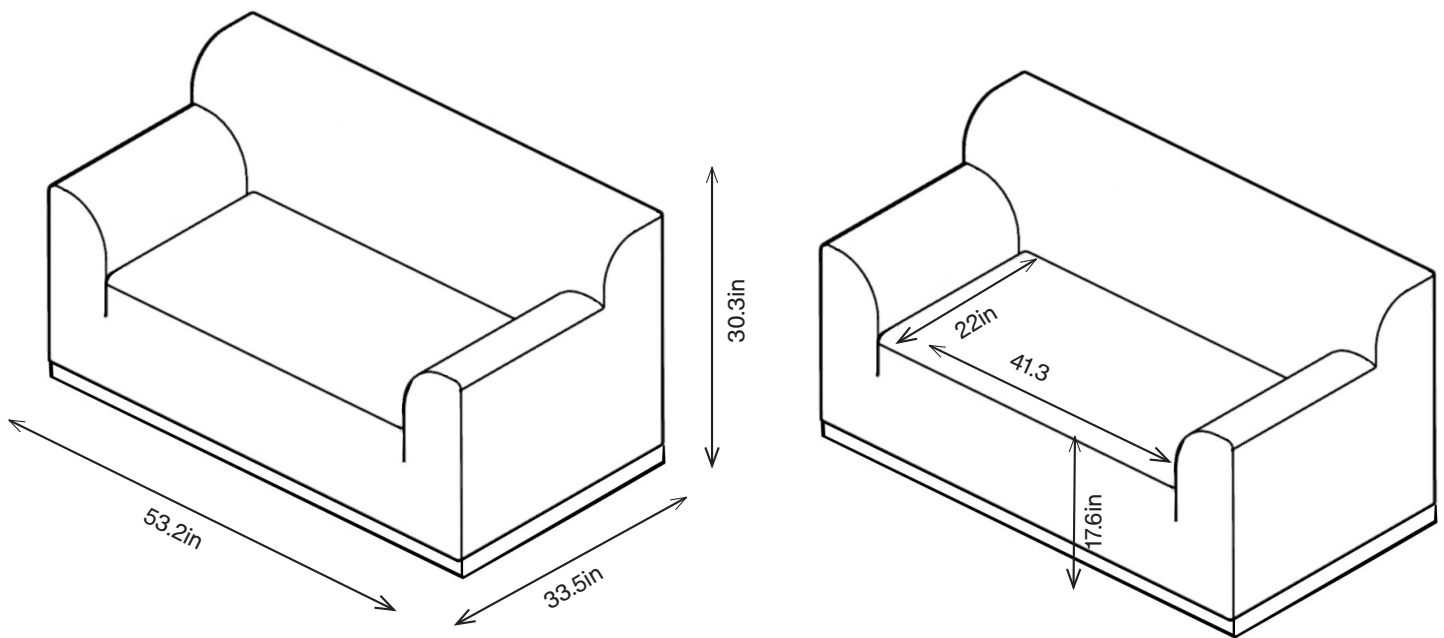

T

800.496.9324

E

[inquiries@pineapplecontracts.com](mailto:inquiries@pineapplecontracts.com)

W

[us.pineapplecontracts.com](http://us.pineapplecontracts.com)

# Pineapple